



## KL38.8

### Wheel loaders

#### EXTERNALLY ROBUST AND INTERNALLY COMFORTABLE

The Kramer KL38.8 is a wheel loader of the Premium 8 Series range and is equipped with the tried-and-tested principle of the one-piece frame. Alongside the great maneuverability, the machine is impressive in both performance and comfort. The optionally available ecospeed transmission, the tractor approval, and the trailer coupling enable efficient operation in any situation. The modern cab design with the fold-down armrest is also impressive in terms of ergonomics and comfort.

**Optimal tractor:** With optional trailer coupling and corresponding EC tractor approval

**7-inch LCD display:** The optional 7" display contains various displays, setting options and assistance systems

**Smart Attach:** Hydraulic attachments can be changed quickly, simply, and safely as a result of the series' installed full-hydraulic quickhitch plate

**Fuel savings:** The correct selection of the four driving modes (Power, Eco, Road, CSD) can save up to 10% fuel

**Smart Steering:** Adjust the required turns of the steering wheel individually: achieve more steering angle with fewer steering movements

## Technical Data

### ■ Standard engine data

Engine manufacturer	Deutz
Drive output	55.4 kW
Drive output	75 PS
Cylinder capacity	2,924 cm <sup>3</sup>
Exhaust standard level	V
Exhaust aftertreatment	DOC / DPF

### ■ Weights

Bucket capacity (standard bucket)	0.95 m <sup>3</sup>
Payload (max.)	1,710 kg
Operating weight	5,000 - 5,600 kg
Payload (S=1.25)	2,300 kg
Tipping load (standard bucket)	3,890 kg
Tipping load (pallet fork)	2,870 kg

### ■ Filling levels

Tank capacity for fuel	85 l
Tank capacity for hydraulic oil	50 l

### ■ Drive system

Travel speed Standard	0-20 km/h
Travel speed Option 1	0-30 km/h
Travel speed Option 2	0-40 km/h
Differential lock	100 % front axle + rear axle

### ■ Hydraulic system

Work hydraulics discharge volume (max.)	70 l/min
---	----------

### ■ Kinematics

Kinematics type	P
Quick change system	Kramer HV/WL-C; includes Smart Attach

### ■ Steering

Steering angle max.	40 degree
---------------------	-----------

### ■ Noise characteristic values

Guaranteed sound power level LwA (operator's canopy)	101 dB(A)
Measured sound power level LwA	99.4 dB(A)
Sound pressure level at the operator's ear	74 dB(A)

## Dimensions

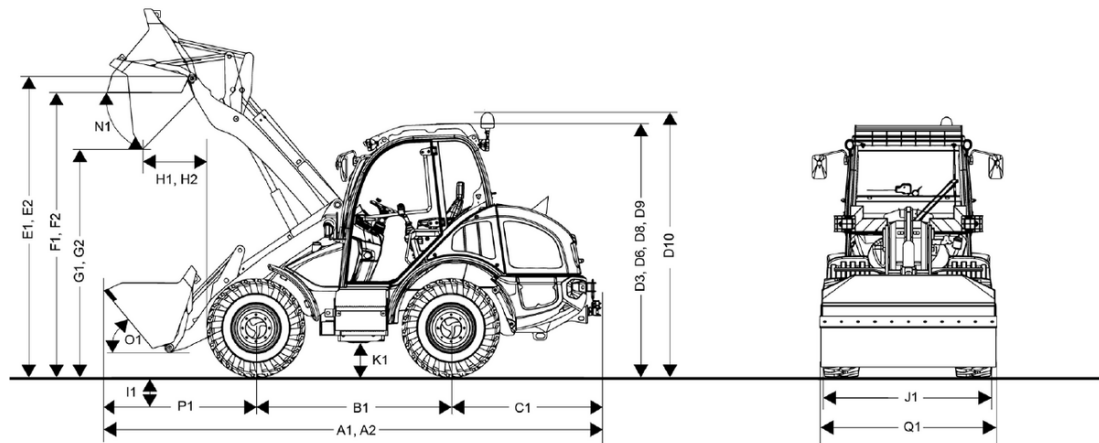

A2	Total length with standard attachment / extended loading system	5,665 mm
A1	Total length with standard attachment	5,359 mm
B1	Wheel base center	2,020 mm
C1	Rear overhang	1,490 mm
D3	Height with cab	2,490 mm
D6	Height with air-conditioning system	2,575 mm
D10	Total height with rotating beacon	2,765 mm
E1	Max. height blade pivot point	3,350 mm
E2	Max. height of hinge pin height / extended loading system	3,500 mm
F1	Load-over height	3,200 mm
F2	Load-over height / extended loading system	3,350 mm
G1	Dumping height	2,680 mm
G2	Dumping height / extended loading system	2,810 mm
H1	Dumping width	540 mm
H2	Dumping range / extended loading system	730 mm
I1	Digging depth	45 mm
K1	Ground clearance	330 mm
L1	Turning radius outer edge wheels	2,840 mm
M1	Steering angle	40 °
M2	Swing angle	22 °
N1	Dumping angle at max. lifting height	41 °
O1	Dumping angle at ground level	50 °
P1	Distance center front axle to tooth tip	1,860 mm
Q1	Bucket width	2,050 mm
R1	Stacking height	3,130 mm
R2	Stacking height / extended loading system	3,280 mm
D8	Height with panoramic cab	2,530 mm
D9	Height with panoramic cab and air-conditioning system	2,575 mm