



5035 Wheel Loader

Practical. Safe. Intelligent.

The 5035, from Kramer's compact class, is agile in its movement, dynamic in its power delivery and slim in its design. With its optimized power-to-weight ratio, low transport weight and consistently high payload, it is the ideal helper on construction sites in road building, civil engineering, horticulture and landscaping. With its dimensions, it is also predestined for low clearance heights and narrow passages. Due to a width of only 1.26 m, driving on a sidewalk is effortless. In addition, due to the low transport weight, the machine can also be transported on a car trailer and thus a quick transfer to different places of use is no problem.

Front axle and crab steering: The crabwalk not only enables the optimal reaching of the obstacles but also keeps the constant distance in parallel.

Comfortable cabin design: A wide entrance with additional step ensures comfortable and, above all, safe entry and exit.

Loading system with Z-kinematics: The Z-kinematics enable large lifting forces as well as tearing forces and exact parallel guidance over the entire height. The visual position indicator for attachments is ideal for inexperienced operators.

Openable cabin door: The generously designed window on the right side can be opened by 180 ° as usual. In addition to this, the cabin door can also be set up just so.

Ergonomics: The side console, redesigned from the ground up, contains numerous storage compartments in addition to many functional and ergonomic features. All important switches are located in the grip area of the right hand.

Technical Data

■ Standard engine data

Engine manufacturer	Yanmar
Drive output	18.5 kW
Drive output	25.2 PS
at max. rpm	2,500 U/min
Cylinder capacity	1,331 cm ³

■ Weights

Bucket capacity (standard bucket)	0.35 m ³
Payload (max.)	570 kg
Operating weight	1,700 - 2,200 kg
Payload (S=1.25)	750 kg
Thrusting force (max.)	1,160 daN
Lift capacity (max.)	11.5 kN
Tipping load (standard bucket)	1,140 kg
Tipping load (pallet fork)	930 kg
Tipping load (pallet fork)*	1,189 kg

■ Filling levels

Tank capacity for fuel	48 l
Tank capacity for hydraulic oil	39 l

■ Drive system

Travel speed Standard	0-20 km/h
-----------------------	-----------

■ Hydraulic system

Work hydraulics discharge volume (max.)	20 l/min
---	----------

■ Kinematics

Kinematics type	Z
-----------------	---

■ Steering

Steering angle max.	38 degree
---------------------	-----------

■ Noise characteristic values

Guaranteed sound power level LwA (operator's canopy)	101 dB(A)
Measured sound power level LwA	97.4 dB(A)
Sound pressure level at the operator's ear	80 dB(A)

Dimensions

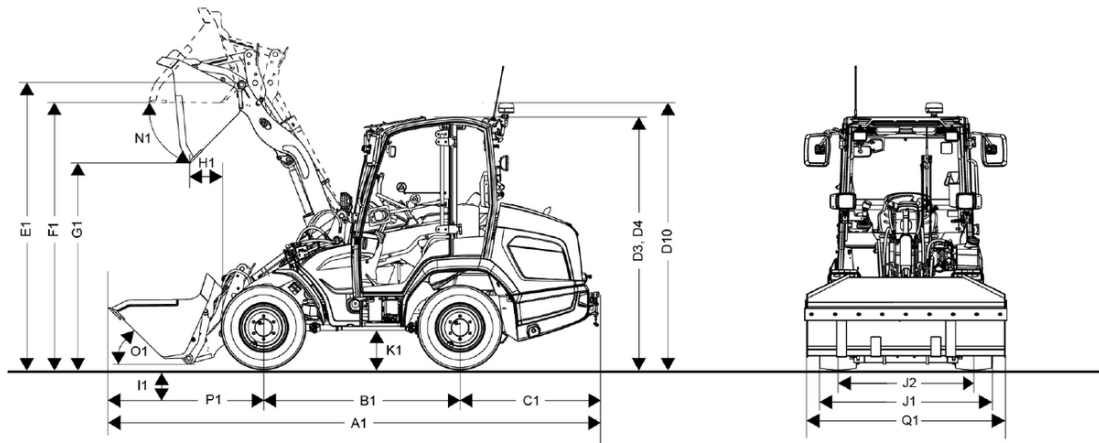

A1	Total length with standard attachment	4,050 mm
B1	Wheel base center	1,525 mm
C1	Rear overhang	1,140 mm
D2	Height with canopy down	2,020 mm
D3	Height with cab	2,170 mm
D4	Height with cab lowered	2,020 mm
D10	Total height with rotating beacon	2,490 mm
E1	Max. height blade pivot point	2,800 mm
F1	Load-over height	2,680 mm
G1	Dumping height	2,290 mm
I1	Digging depth	60 mm
J1	Total width	1,240 mm
J2	Track width	970 mm
L1	Turning radius outer edge wheels	2,000 mm
M1	Steering angle	38 °
M2	Swing angle	14 °
N1	Dumping angle at max. lifting height	40 °
O1	Dumping angle at ground level	43 °
P1	Distance center front axle to tooth tip	1,390 mm
Q1	Bucket width	1,250 mm
R1	Stacking height	2,630 mm