



5040 Wheel Loader

The energy package with best dimensions.

The wheel loader model 5040 is equipped as standard with a 28.5 kW / 38.8 hp Yanmar engine. Exhaust gas aftertreatment is provided by DOC and DPF. In addition, Smart Driving PRO is optionally available for the all-wheel steer wheel loader. This is a feature with three different driving modes that support and relieve the driver in the respective applications and are also fuel-saving. Combined with the narrow width of 1.26 m, this makes the 5040 the ideal companion for road construction, civil engineering, landscaping and gardening.

Smart Driving Pro: An optional feature with three different driving modes that support and relieve the driver in the respective applications and are also fuel-efficient.

Modern cabin design: The wide pedal step makes getting on and off even more convenient.

Functional side console: Thoughtfully designed from the ground up, the side console contains numerous storage compartments in addition to many functional and ergonomic features.

Convincing performance data: The working hydraulics with 30 l/min and Powerflow (optional) with 60l/min ensure fast working cycles and the air conditioning provides the necessary comfort.

Bluetooth radio: The optional radio is equipped with USB port and hands-free.

Technical Data

■ Standard engine data

Engine manufacturer	Yanmar
Drive output	28.5 kW
Drive output	38.8 PS
at max. rpm	2,600 U/min
Cylinder capacity	1,568 cm ³
Exhaust aftertreatment	DOC / DPF

■ Weights

Bucket capacity (standard bucket)	0.36 m ³
Payload (max.)	700 kg
Operating weight	1,900 - 2,400 kg
Payload (S=1.25)	900 kg
Thrusting force (max.)	1,160 daN
Lift capacity (max.)	11.6 kN
Tipping load (standard bucket)	1,400 kg
Tipping load (pallet fork)	1,125 kg
Tipping load (pallet fork)*	1,438 kg

■ Filling levels

Tank capacity for fuel	48 l
Tank capacity for hydraulic oil	39 l

■ Drive system

Travel speed Standard	0-20 km/h
Travel speed Option 1	0-30 km/h

■ Hydraulic system

Work hydraulics discharge volume (max.)	30 l/min
---	----------

■ Kinematics

Kinematics type	Z
-----------------	---

■ Steering

Steering angle max.	38 degree
---------------------	-----------

■ Noise characteristic values

Guaranteed sound power level LwA (operator's canopy)	101 dB(A)
Measured sound power level LwA	99.1 dB(A)
Sound pressure level at the operator's ear	80 dB(A)

Dimensions

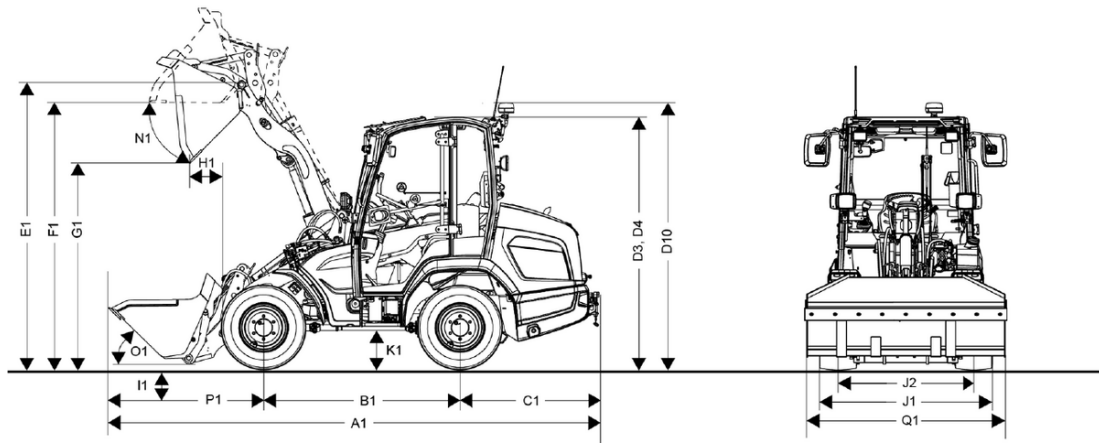

A1	Total length with standard attachment	4,090 mm
B1	Wheel base center	1,525 mm
C1	Rear overhang	1,140 mm
D2	Height with canopy down	2,020 mm
D3	Height with cab	2,170 mm
D4	Height with cab lowered	2,020 mm
D10	Total height with rotating beacon	2,490 mm
E1	Max. height blade pivot point	2,800 mm
F1	Load-over height	2,680 mm
G1	Dumping height	2,260 mm
H1	Dumping width	290 mm
I1	Digging depth	60 mm
J1	Total width	1,240 mm
J2	Track width	970 mm
L1	Turning radius outer edge wheels	2,000 mm
M1	Steering angle	38 °
M2	Swing angle	14 °
N1	Dumping angle at max. lifting height	40 °
O1	Dumping angle at ground level	43 °
P1	Distance center front axle to tooth tip	1,430 mm
Q1	Bucket width	1,400 mm
R1	Stacking height	2,630 mm