



## KL12.5

### Wheel loader

The compact wizard with best dimensions

With a very compact design, KL12.5 is a desired helper in work done in narrow spaces. Given its height, the machine can be used in several ways and therefore facilitates applications in buildings or while driving on pavements. Due to its very low net weight, the wheel loader can be transported without any problems on 3.5 t trailers.

**Compact motor design:** The 18.5 kW engine does not require exhaust gas aftertreatment and complies with exhaust gas stage V.

**Two cabin heights:** Standard 2.02 m and optional 2.17 m

**Ergonomics:** The side console contains numerous storage compartments in addition to many functional and ergonomic features. All important switches are located in the grip area of the right hand

**Comfortable cabin design:** A wide entrance with additional step ensures comfortable and safe entry and exit

**Front axle and crab steering:** The crabwalk not only enables the optimal reaching of the obstacles but also keeps the constant distance in parallel

## Technical Data

### ■ Standard engine data

Engine manufacturer	Yanmar
Drive output	18.5 kW
Drive output	25.2 PS
at max. rpm	2,500 U/min
Cylinder capacity	1,331 cm <sup>3</sup>

### ■ Weights

Bucket capacity (standard bucket)	0.35 m <sup>3</sup>
Payload (max.)	570 kg
Operating weight	1,700 - 2,200 kg
Payload (S=1.25)	750 kg
Thrusting force (max.)	1,160 daN
Lift capacity (max.)	11.5 kN
Tipping load (standard bucket)	1,140 kg
Tipping load (pallet fork)	930 kg
Tipping load (pallet fork)*	1,189 kg

### ■ Filling levels

Tank capacity for fuel	48 l
Tank capacity for hydraulic oil	39 l

### ■ Drive system

Travel speed Standard	0-20 km/h
-----------------------	-----------

### ■ Hydraulic system

Work hydraulics discharge volume (max.)	20 l/min
---	----------

### ■ Kinematics

Kinematics type	Z
-----------------	---

### ■ Steering

Steering angle max.	38 degree
---------------------	-----------

### ■ Noise characteristic values

Guaranteed sound power level L <sub>wA</sub> (operator's canopy)	101 dB(A)
Measured sound power level L <sub>wA</sub>	97.4 dB(A)
Sound pressure level at the operator's ear	80 dB(A)

## Dimensions

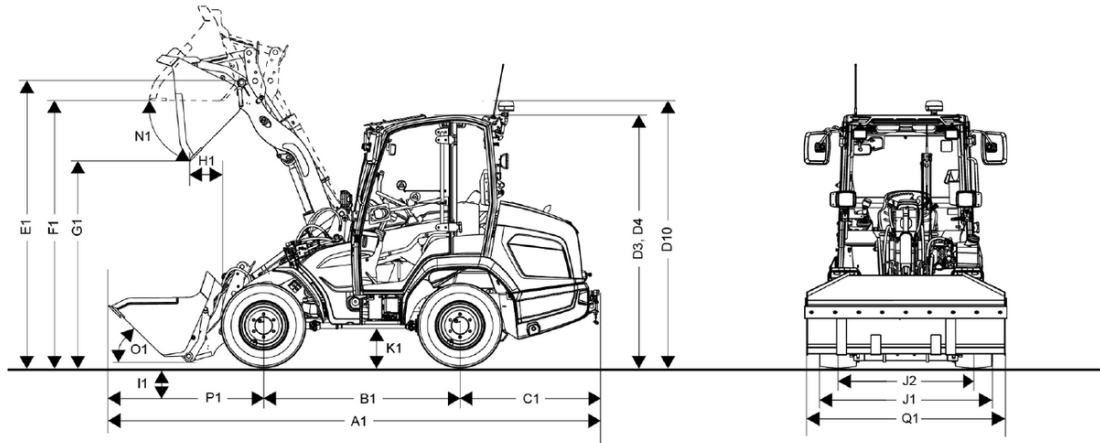

A1	Total length with standard attachment	4,050 mm
B1	Wheel base center	1,525 mm
C1	Rear overhang	1,140 mm
D2	Height with canopy down	2,020 mm
D3	Height with cab	2,170 mm
D4	Height with cab lowered	2,020 mm
D10	Total height with rotating beacon	2,490 mm
E1	Max. height blade pivot point	2,800 mm
F1	Load-over height	2,680 mm
G1	Dumping height	2,290 mm
I1	Digging depth	60 mm
J1	Total width	1,240 mm
J2	Track width	970 mm
L1	Turning radius outer edge wheels	2,000 mm
M1	Steering angle	38 °
M2	Swing angle	14 °
N1	Dumping angle at max. lifting height	40 °
O1	Dumping angle at ground level	20 °
P1	Distance center front axle to tooth tip	1,390 mm
Q1	Bucket width	1,250 mm
R1	Stacking height	2,630 mm